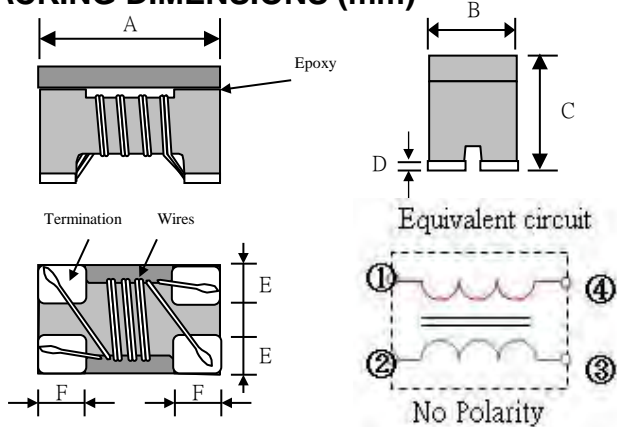

ITEM P/N	DB1210A-SERIES	TEST INSTRUMENT	4287A / 4339B
PRODUCT	COMMON MODE CHOKE	TEST FREQUENCY	100 MHz / 0.5V

**PACKING DIMENSIONS (mm)**

DB1210	Dimensions
A	1.2 ± 0.2
B	1.0 ± 0.2
C	0.9 max.
D	0.15 max.
E	0.36Typ.
F	0.33Typ.

**EXPLANATION OF PART NUMBERS**

1	2	3	4	5	6	7	8	9	10	11	
D	B	1	2	1	0	A	-	6	7	0	S
(1)	(2)	(3)	(4)	(5)							

- (1) Product name  
 (2) Shapes and dimensions  
 (3)Shielding Type

A	Shielding Type for 1 GHz
---	--------------------------

- (4) Impedance 【 at 100MHz 】  
 161:160Ω  
 (5) Tolerance  
 S=±25% ; M=±20%

**ELECTRICAL CHARACTERISTICS**

P/N	Z(Ω)	DCR (Ω)	Idc(mA)	Rated Voltage	Insulation Resistance	Cut-off Frequency	Characteristic Resistance
	Common Mode						
	Impedance at 100MHz	[ Max ]	[ Max ]	Vdc (V)Typical	IR (MΩ)Min.	(GHz)	(Ω)
DB1210A-670□	67	0.40	300	20	10	1.0 typ.	—
DB1210A-900□	90	0.50	280	20	10	1.0 typ.	—
DB1210A-121□	120	0.55	270	20	10	1.0 typ.	—
DB1210A-161□	160	0.58	260	20	10	1.0 typ.	—
DB1210A-181□	180	0.60	260	20	10	1.0 typ.	—
DB1210A-251□	250	0.70	230	20	10	1.0 typ.	—
DB1210A-331□	330	0.80	200	20	10	1.0 typ.	—

Operating temperature : -25 to +85°C

Storage temp. and humidity : -40 to +85°C ,70%RH max

If Use Wave soldering is there will be some risk. Re-flow soldering temperatures below 240 degrees, there will be unwitting risk

ITEM P/N	DB1210A-SERIES	TEST INSTRUMENT	4287A / 4339B
PRODUCT	COMMON MODE CHOKE	TEST FREQUENCY	100 MHz / 0.5V

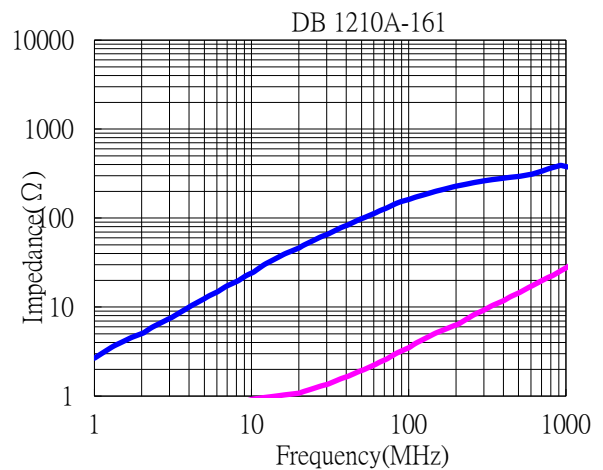
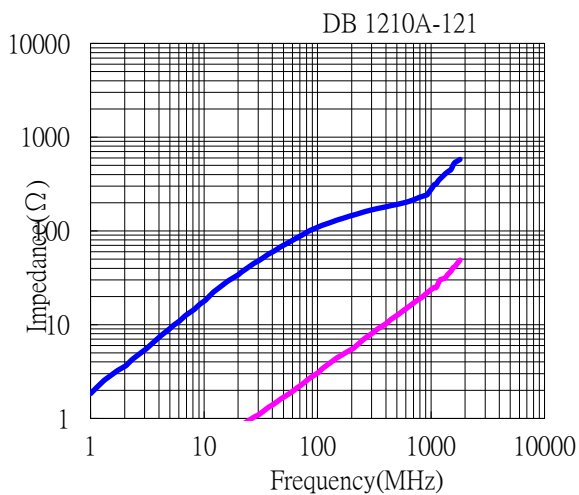
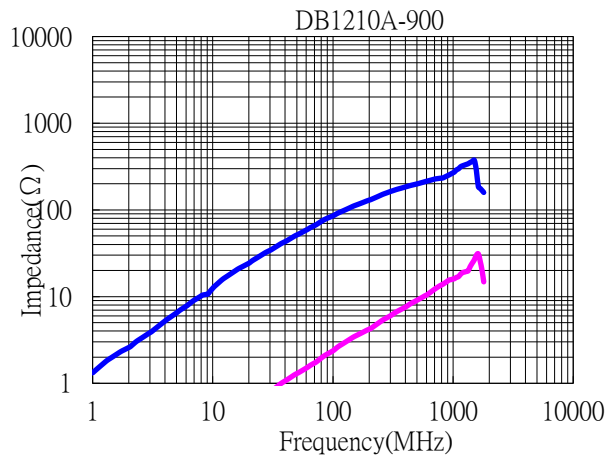
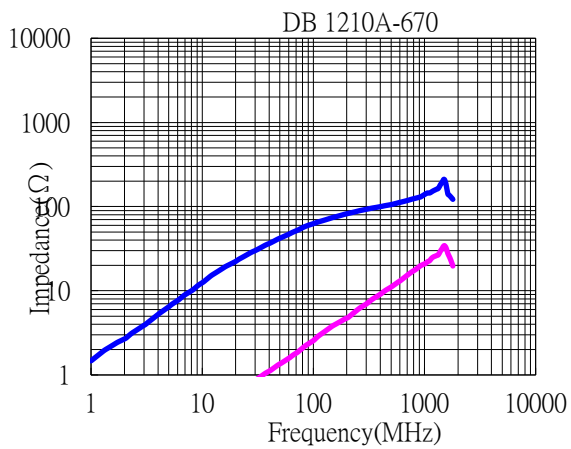
**PERFORMANCE CURVES**

<b>ITEM P/N</b>	<b>DB1210A-SERIES</b>	<b>TEST INSTRUMENT</b>	<b>4287A / 4339B</b>
<b>PRODUCT</b>	<b>COMMON MODE CHOKE</b>	<b>TEST FREQUENCY</b>	<b>100 MHz / 0.5V</b>

## PERFORMANCE CURVES

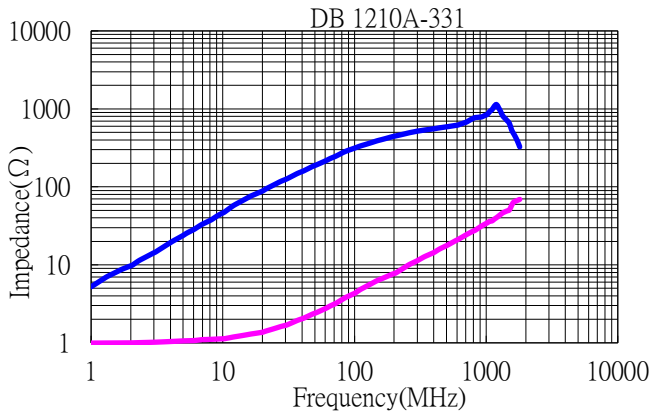
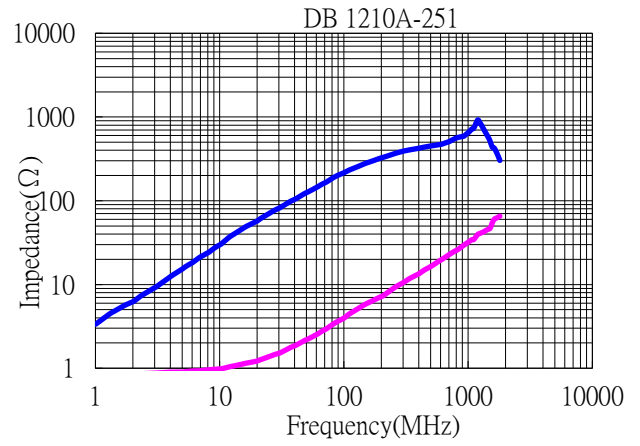
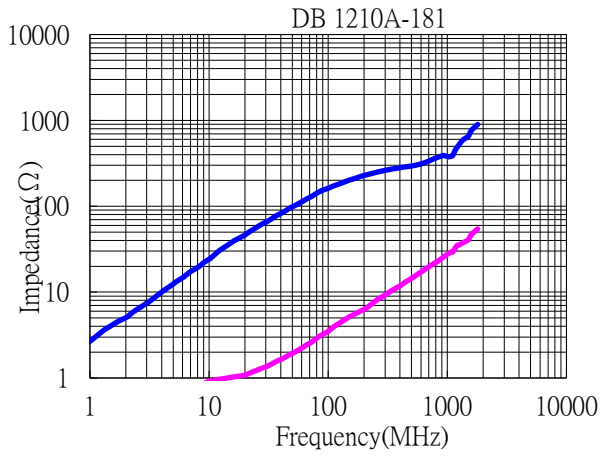

## Equivalent Circuit & Recommended Footprint

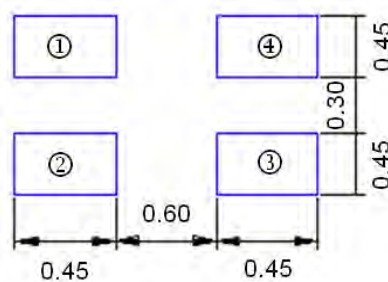
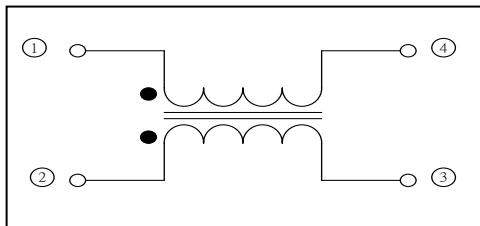

ITEM P/N	DB1210A-SERIES	TEST INSTRUMENT	4287A / 4339B
PRODUCT	COMMON MODE CHOKE	TEST FREQUENCY	100 MHz / 0.5V

**Test Equipment****Impedance**

Measured by using Agilent 4291A RF Impedance Analyzer.

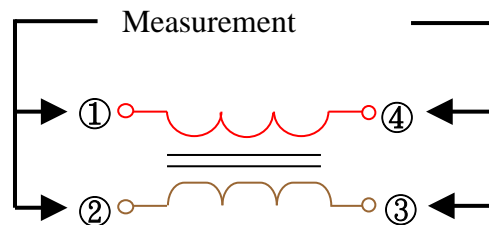
**DC Resistance**

Measured by using Chroma 16502 mill ohm meter.

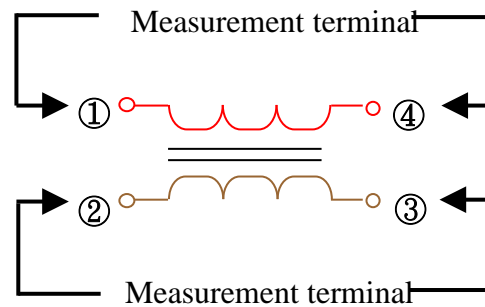
**Insulation Resistance**

Measured by using Chroma 19073

Measurement voltage : 50v ,Measurement time : 60 sec.

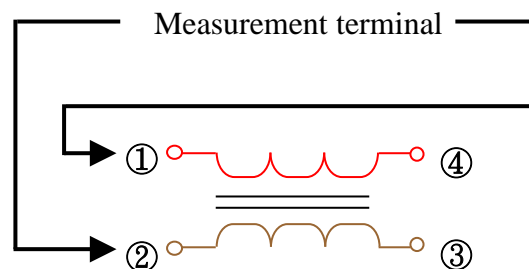

ITEM P/N	DB1210A-SERIES	TEST INSTRUMENT	4287A / 4339B
PRODUCT	COMMON MODE CHOKE	TEST FREQUENCY	100 MHz / 0.5V

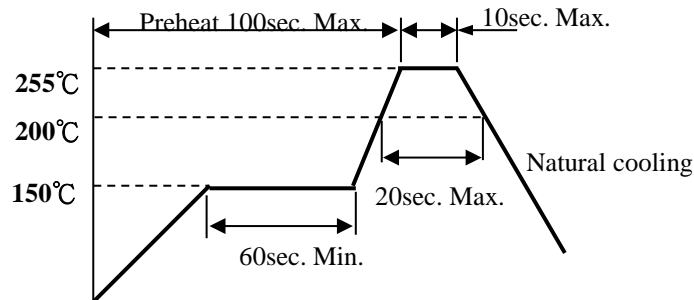
**RECOMMENDED SOLDERING TEMP. GRAPH****MECHANICAL RELIABILITY**

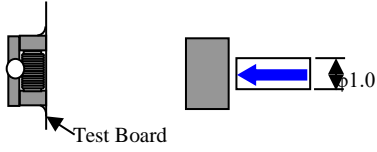
TEST	Specification & Requirement	Method Used
Solderability	The surface of terminal/pin tested shall be covered with new solder by 90%	Solder heat proof: Preheating: 150 ±10°C 60 seconds Soldering: 245 ±5°C for 4 ±1 sec
Solder Heat Resistance	Components should have not evidence of electrical and mechanical damage Impedance: within ±15% of initial value	Preheating: 150°C 60secs Solder temperature: 260±5°C Flux: rosin Dip time: 10±0.5 secs
Terminal strength	Series No.	F (Kg)
	DB1210A/D	0.2
	DB1608A/C	0.5
	DB2012A/B/C	0.5
	DB3216A	1.0
		Solder a chip to test substrate and then laterally apply a force in the arrow direction 

**ENDURANCE RELIABILITY**

TEST	Specification & Requirement	Method Used
Thermal Shock	Impedance change within ± 15% Without mechanical damage	-65°C, (30 mins) -> room temp. (2 mins) -> 125°C, (30 mins) -> room temp. (2 mins) 50 cycles
Humidity Resistance	Impedance change within ± 15% Without mechanical damage	Apply IDC current @ 60°C ambient Humidity: 90% Duration: 168 hrs
Low Temp. Storing	Impedance change within ± 15% Without mechanical damage	Storing Temp. -40 ±2 °C for total 168 +5/-0 hours
High Temp. Storing	Impedance change within ± 15% Without mechanical damage	Storing Temp. 125 ±2 °C for total 168 +5/-0 hours

ITEM P/N	DB1210A-SERIES	TEST INSTRUMENT	4287A / 4339B
PRODUCT	COMMON MODE CHOKE	TEST FREQUENCY	100 MHz / 0.5V

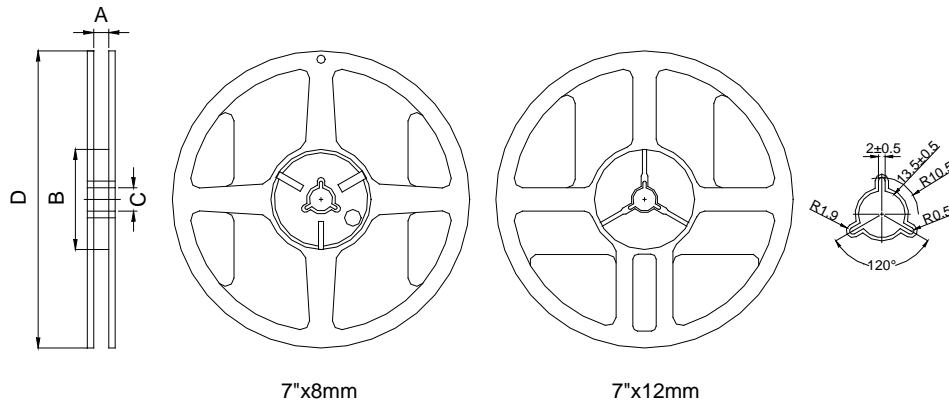
**Reel Dimension & Tape Dimension**

Type	A(mm)	B(mm)	C(mm)	D(mm)
7"x8mm	9.0±0.5	60±2	13.5±0.5	178±2
7"x12mm	13.5±0.5	60±2	13.5±0.5	178±2

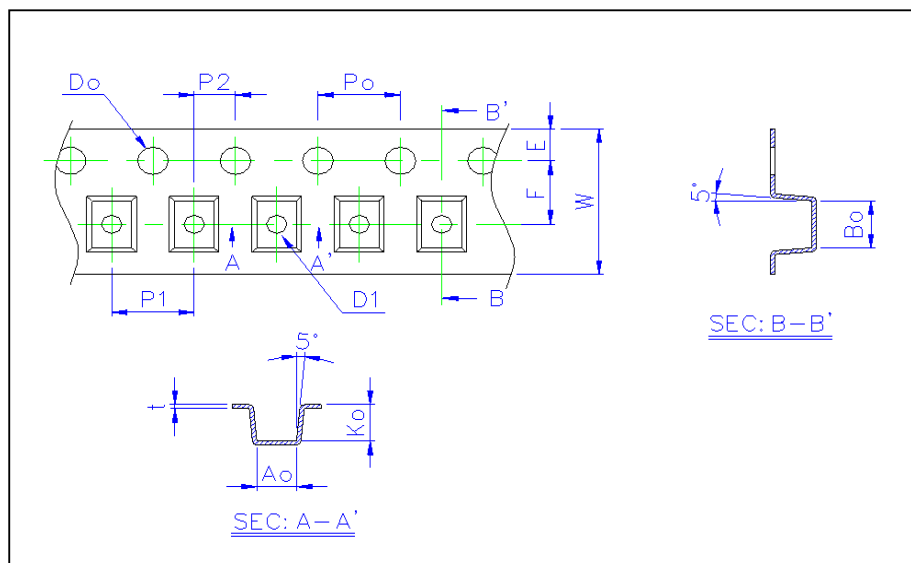

Size	Ao(mm)	Bo(mm)	Ko(mm)	W(mm)	E(mm)	F(mm)	Po(mm)	P1(mm)	Do(mm)
1210	1.15±0.10	1.40±0.10	0.93±0.10	8.00±0.20	1.75±0.10	3.50±0.05	4.0±0.05	4.0±0.10	1.5+0.1,-0
1608	1.00±0.10	1.65±0.10	1.18±0.10	8.00±0.20	1.75±0.10	3.50±0.05	4.0±0.05	4.0±0.10	1.5+0.1,-0
2012	1.50±0.10	2.35±0.10	1.45±0.10	8.00±0.20	1.75±0.10	3.50±0.05	4.0±0.05	4.0±0.10	1.5+0.1,-0
3216	1.88±0.10	3.50±0.10	2.10±0.10	8.00±0.20	1.75±0.10	3.50±0.05	4.0±0.05	4.0±0.10	1.5+0.1,-0

**Packaging Quantity**

Chip Size	1210	1608	2012	3216
8mm/ Reel	3000	2000	2000	2000