



## Ni-Zn SOFT FERRITE CORES-T-Series

### T-Series For EMI suppression

#### Features

1. One hole rod type
2. Excellent heat resistance.
3. Available in various sizes & materials.
4. High reliability



#### Applications

- E.M.I. Suppression on round cable.
1. Computer and peripheral products
  2. Consumer electronic products
  3. Communication electronic products
  4. Measuring instruments

#### Shapes and Dimensions (mm)

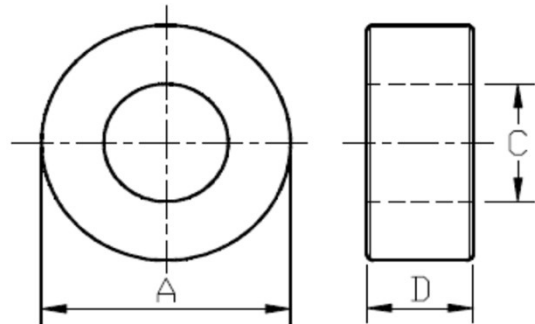

#### Product Identification

M2L T 4×5×2 - PF

M2L:Material Type CODE

T: SERIES NAME

4: DIMENSION SIZE CODE=A

5: DIMENSION SIZE CODE=D

2: DIMENSION SIZE CODE=C

PF:Pb-Free













# Ni-Zn SOFT FERRITE CORES-T-Series

## T-Series For EMI suppression

### Impedance Vs Frequency

