



SMD Power chokes- SGRH -D Series

SGRH -D series chokes For High Energy Storage & Lower Power losses Use

Features

1. Available in magnetically shielded.
2. Low DC resistance.
3. Suitable for large currents.
4. Ideal for a variety of DC - DC converter inductor applications.
5. Available on tape and reel for auto surface mounting.



Applications

- Power supply for VTRs.OA equipment.
- LCD televisions.Notebook PCs.
- Portable communication equipment.
- DC / DC converters, etc.

Dimensions (mm)

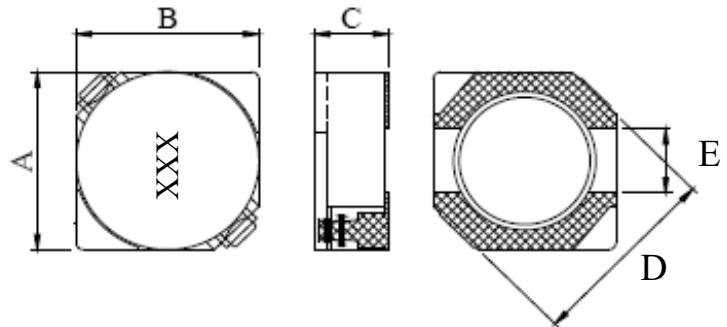

Product Identification

SGRH 3D16- 1R2 M -PF

SGRH: SERIES NAME

3D16: DIMENSION SIZE CODE

D: CORE TYPE

1R2: INDUCTANCE CODE.

M: TOLERANCE, K=10% M=20%.±30%(N)

PF:Pb-Free

SERIES	A	B	C	D	E
SGRH2D08	3.2Max	3.2Max	0.9Max	3.3REF	1.0REF
SGRH2D11	3.2Max	3.2Max	1.2Max	3.3REF	1.0REF
SGRH2D14	3.2Max	3.2Max	1.6Max	3.3REF	1.0REF
SGRH2D18	3.2Max	3.2Max	2.0Max	3.3REF	1.0REF
SGRH3D16	4.2Max	4.2Max	2.0Max	4.4REF	1.2REF
SGRH4D18	5.2Max	5.2Max	2.0Max	6.9REF	1.5REF
SGRH4D28	5.2Max	5.2Max	3.0Max	6.9REF	1.5REF
SGRH5D18	6.2Max	6.2Max	2.0Max	8.2REF	2.0REF
SGRH5D28	6.2Max	6.2Max	3.0Max	8.2REF	2.0REF
SGRH6D28	7.2Max	7.2Max	3.0Max	9.5REF	2.0REF
SGRH6D38	7.2Max	7.2Max	4.0Max	9.5REF	2.0REF

RECOMMENDER P.C.B LAYOUT

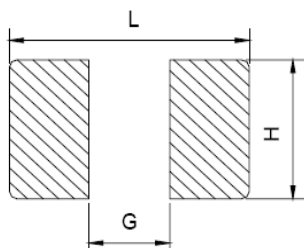

SERIES	L	H	G
SGRH2DXX	4.3	4.3	1.0
SGRH3DXX	4.6	4.6	1.1
SGRH4DXX	5.3	5.3	1.5
SGRH5DXX	6.3	6.3	2.0
SGRH6DXX	7.3	7.3	2.0

SMD POWER CHOKE-SGRH Series
Electrical Characteristics

Part Number	Inductance (uH)	Test Frequency (KHz)	DC Resistance (ΩMax)	Rated current (A)Max	Itemp (A)Max
SGRH2D08-2R2□-PF	2.2	100	0.22	0.7	1.0
SGRH2D08-3R3□-PF	3.3	100	0.34	0.6	0.9
SGRH2D08-4R7□-PF	4.7	100	0.48	0.4	0.7
SGRH2D08-6R8□-PF	6.8	100	0.42	0.3	0.5
SGRH2D08-100□-PF	10	100	0.64	0.2	0.3
SGRH2D08-220□-PF	22	100	2.55	0.15	0.2

Note:

- (1). All test data is referenced to 25°C ambient.
- (2). Operating Temperature Range-25°C to +105°C.
- (3). DC current(A)that will cause an approximate ΔT of 40°C.
- (4). DC current(A)that will cause Lo to drop approximately 35%.
- (5). □Tolerance of inductance $\pm 20\%$ (M) $\pm 30\%$ (N)

SMD POWER CHOKE-SGRH Series
Electrical Characteristics

Part Number	Inductance (uH)	Test Frequency (KHz)	DC Resistance (ΩMax)	Rated current (A)Max	Itemp (A)Max
SGRH2D11-1R5□-PF	1.5	100	0.10	0.80	1.45
SGRH2D11-2R2□-PF	2.2	100	0.15	0.70	1.27
SGRH2D11-3R3□-PF	3.3	100	0.19	0.60	1.14
SGRH2D11-4R7□-PF	4.7	100	0.27	0.50	1.02
SGRH2D11-6R8□-PF	6.8	100	0.42	0.40	0.86
SGRH2D11-100□-PF	10	100	0.56	0.35	0.70
SGRH2D11-120□-PF	12	100	0.6	0.3	0.56
SGRH2D11-150□-PF	15	100	0.65	0.24	0.50
SGRH2D11-180□-PF	18	100	0.75	0.22	0.45
SGRH2D11-220□-PF	22	100	1.2	0.20	0.43
SGRH2D11-330□-PF	33	100	1.87	0.18	0.38
SGRH2D11-470□-PF	47	100	2.35	0.15	0.34

Note:

- (1). All test data is referenced to 25°C ambient.
- (2). Operating Temperature Range-25°C to +105°C.
- (3). DC current(A)that will cause an approximate ΔT of 40°C.
- (4). DC current(A)that will cause Lo to drop approximately 35%.
- (5). □Tolerance of inductance $\pm 20\%$ (M) $\pm 30\%$ (N)

SMD POWER CHOKE-SGRH Series
Electrical Characteristics

Part Number	Inductance (uH)	Test Frequency (KHz)	DC Resistance (ΩMax)	Rated current (A)Max	Itemp (A)Max
SGRH2D14-1R5□-PF	1.5	100	0.10	0.80	1.60
SGRH2D14-2R2□-PF	2.2	100	0.15	0.70	1.44
SGRH2D14-3R3□-PF	3.3	100	0.19	0.60	1.10
SGRH2D14-4R7□-PF	4.7	100	0.27	0.50	0.90
SGRH2D14-6R8□-PF	6.8	100	0.42	0.40	0.70
SGRH2D14-100□-PF	10	100	0.56	0.30	0.65
SGRH2D14-220□-PF	22	100	1.20	0.20	0.50

Note:

- (1). All test data is referenced to 25°C ambient.
- (2). Operating Temperature Range-25°C to +105°C.
- (3). DC current(A)that will cause an approximate ΔT of 40°C.
- (4). DC current(A)that will cause Lo to drop approximately 35%.
- (5). □Tolerance of inductance $\pm 20\%$ (M) $\pm 30\%$ (N)



SMD POWER CHOKE-SGRH Series

Electrical Characteristics

Part Number	Inductance (uH)	Test Frequency (KHz)	DC Resistance (Ω Max)	Rated current (A)Max	Itemp (A)Max
SGRH2D18-2R2□-PF	2.2	100	0.075	0.80	2.00
SGRH2D18-3R3□-PF	3.3	100	0.09	0.70	1.80
SGRH2D18-4R7□-PF	4.7	100	0.13	0.60	1.40
SGRH2D18-6R8□-PF	6.8	100	0.18	0.50	1.20
SGRH2D18-100□-PF	10	100	0.25	0.40	1.00
SGRH2D18-150□-PF	15	100	0.38	0.30	0.90
SGRH2D18-220□-PF	22	100	0.55	0.20	0.70
SGRH2D18-330□-PF	33	100	0.87	0.10	0.50
SGRH2D18-470□-PF	47	100	1.77	0.10	0.40

Note:

- (1). All test data is referenced to 25°C ambient.
- (2). Operating Temperature Range-25°C to +105°C.
- (3). DC current(A)that will cause an approximate ΔT of 40°C.
- (4). DC current(A)that will cause Lo to drop approximately 35%.
- (5). □Tolerance of inductance $\pm 20\%$ (M) $\pm 30\%$ (N)



SMD POWER CHOKE-SGRH Series

Electrical Characteristics

Part Number	Inductance (uH)	Test Frequency (KHz)	DC Resistance (Ω Max)	Rated current (A)Max	Itemp (A)Max
SGRH3D16-1R5□-PF	1.5	100	0.052	1.55	2.25
SGRH3D16-2R2□-PF	2.2	100	0.072	1.20	1.80
SGRH3D16-3R3□-PF	3.3	100	0.085	1.10	1.60
SGRH3D16-4R7□-PF	4.7	100	0.105	0.90	1.41
SGRH3D16-6R8□-PF	6.8	100	0.17	0.73	1.14
SGRH3D16-100□-PF	10	100	0.21	0.55	1.08
SGRH3D16-150□-PF	15	100	0.295	0.42	0.92
SGRH3D16-220□-PF	22	100	0.43	0.35	0.78
SGRH3D16-330□-PF	33	100	0.675	0.32	0.62
SGRH3D16-470□-PF	47	100	0.94	0.22	0.52
SGRH3D16-680□-PF	68	100	1.28	0.20	0.44
SGRH3D16-820□-PF	82	100	1.55	0.17	0.41
SGRH3D16-101□-PF	100	100	1.95	0.15	0.35

Note:

- (1). All test data is referenced to 25°C ambient.
- (2). Operating Temperature Range-25°C to +105°C.
- (3). DC current(A)that will cause an approximate ΔT of 40°C.
- (4). DC current(A)that will cause Lo to drop approximately 35%.
- (5). □Tolerance of inductance $\pm 10\%$ (K) $\pm 20\%$ (M) $\pm 30\%$ (N)

SMD POWER CHOKE-SGRH Series
Electrical Characteristics

Part Number	Inductance (uH)	Test Frequency (KHz)	DC Resistance (ΩMax)	Rated current (A)Max	Itemp (A)Max
SGRH4D18-1R0□-PF	1	100	35m	1.72	3.60
SGRH4D18-2R2□-PF	2.2	100	58m	1.32	2.70
SGRH4D18-2R7□-PF	2.7	100	80m	1.28	2.40
SGRH4D18-3R3□-PF	3.3	100	85m	1.04	2.10
SGRH4D18-3R9□-PF	3.9	100	120m	0.88	1.79
SGRH4D18-4R7□-PF	4.7	100	125m	0.84	1.70
SGRH4D18-5R6□-PF	5.6	100	145m	0.80	1.35
SGRH4D18-6R8□-PF	6.8	100	170m	0.76	1.28
SGRH4D18-8R2□-PF	8.2	100	190m	0.68	1.10
SGRH4D18-100□-PF	10	100	200m	0.61	1.08
SGRH4D18-120□-PF	12	100	210m	0.56	1.00
SGRH4D18-150□-PF	15	100	240m	0.50	0.95
SGRH4D18-180□-PF	18	100	338m	0.48	0.90
SGRH4D18-220□-PF	22	100	397m	0.41	0.80
SGRH4D18-270□-PF	27	100	441m	0.35	0.72
SGRH4D18-330□-PF	33	100	694m	0.32	0.66
SGRH4D18-390□-PF	39	100	709m	0.30	0.59

Note:

- (1). All test data is referenced to 25°C ambient.
- (2). Operating Temperature Range-25°C to +105°C.
- (3). DC current(A)that will cause an approximate ΔT of 40°C.
- (4). DC current(A)that will cause L_o to drop approximately 35%.
- (5). □Tolerance of inductance $\pm 10\%$ (K) $\pm 20\%$ (M) $\pm 30\%$ (N)



SMD POWER CHOKE-SGRH Series

Electrical Characteristics

Part Number	Inductance (uH)	Test Frequency (KHz)	DC Resistance (Ω Max)	Rated current (A)Max	Itemp (A)Max
SGRH4D28-1R2□-PF	1.2	100	23.6m	2.56	5.00
SGRH4D28-1R8□-PF	1.8	100	27.5m	2.20	4.00
SGRH4D28-2R2□-PF	2.2	100	31.3m	2.04	3.60
SGRH4D28-2R7□-PF	2.7	100	43.3m	1.60	3.24
SGRH4D28-3R3□-PF	3.3	100	49.2m	1.57	2.91
SGRH4D28-3R9□-PF	3.9	100	64.8m	1.44	2.61
SGRH4D28-4R7□-PF	4.7	100	72.0m	1.32	2.32
SGRH4D28-5R6□-PF	5.6	100	100.9m	1.17	2.08
SGRH4D28-6R8□-PF	6.8	100	108.9m	1.12	1.87
SGRH4D28-8R2□-PF	8.2	100	117.5m	1.04	1.77
SGRH4D28-100□-PF	10	100	128.5m	1.00	1.51
SGRH4D28-120□-PF	12	100	131.6m	0.84	1.50
SGRH4D28-150□-PF	15	100	149.0m	0.76	1.48
SGRH4D28-180□-PF	18	100	166.0m	0.72	1.42
SGRH4D28-220□-PF	22	100	235.0m	0.70	1.17
SGRH4D28-270□-PF	27	100	261.0m	0.58	1.05
SGRH4D28-330□-PF	33	100	378.0m	0.56	0.95
SGRH4D28-390□-PF	39	100	383.7m	0.50	0.81
SGRH4D28-470□-PF	47	100	587.0m	0.48	0.73
SGRH4D28-560□-PF	56	100	624.5m	0.41	0.66
SGRH4D28-680□-PF	68	100	699.0m	0.35	0.60
SGRH4D28-820□-PF	82	100	914.8m	0.32	0.57
SGRH4D28-101□-PF	100	100	1.02	0.29	0.51
SGRH4D28-121□-PF	120	100	1.27	0.27	0.48
SGRH4D28-151□-PF	150	100	1.35	0.24	0.46
SGRH4D28-181□-PF	180	100	1.54	0.22	0.44

- Note:
- (1). All test data is referenced to 25°C ambient.
 - (2). Operating Temperature Range-25°C to +105°C.
 - (3). DC current(A)that will cause an approximate ΔT of 40°C.
 - (4). DC current(A)that will cause Lo to drop approximately 35%.
 - (5). □Tolerance of inductance $\pm 10\%$ (K) $\pm 20\%$ (M) $\pm 30\%$ (N)

SMD POWER CHOKE-SGRH Series
Electrical Characteristics

Part Number	Inductance (uH)	Test Frequency (KHz)	DC Resistance (Ω Max)	Rated current (A)Max	Itemp (A)Max
SGRH5D18-4R1□-PF	4.1	10	57m	1.95	1.95
SGRH5D18-5R4□-PF	5.4	10	76m	1.60	1.85
SGRH5D18-6R2□-PF	6.2	10	96m	1.40	1.75
SGRH5D18-8R9□-PF	8.9	10	116m	1.25	1.57
SGRH5D18-100□-PF	10	10	0.124	1.20	1.41
SGRH5D18-120□-PF	12	10	0.153	1.10	1.37
SGRH5D18-150□-PF	15	10	0.196	0.97	1.34
SGRH5D18-180□-PF	18	10	0.21	0.85	1.10
SGRH5D18-220□-PF	22	10	0.29	0.80	1.00
SGRH5D18-270□-PF	27	10	0.33	0.75	0.90
SGRH5D18-330□-PF	33	10	0.386	0.65	0.81
SGRH5D18-390□-PF	39	10	0.52	0.57	0.77
SGRH5D18-470□-PF	47	10	0.595	0.54	0.73
SGRH5D18-560□-PF	56	10	0.665	0.50	0.65
SGRH5D18-680□-PF	68	10	0.84	0.43	0.62
SGRH5D18-820□-PF	82	10	0.978	0.41	0.55
SGRH5D18-101□-PF	100	10	1.2	0.36	0.50

Note:

- (1). All test data is referenced to 25°C ambient.
- (2). Operating Temperature Range-25°C to +105°C.
- (3). DC current(A)that will cause an approximate ΔT of 40°C.
- (4). DC current(A)that will cause L_o to drop approximately 35%.
- (5). □Tolerance of inductance $\pm 10\%$ (K) $\pm 20\%$ (M) $\pm 30\%$ (N)

SMD POWER CHOKE-SGRH Series
Electrical Characteristics

Part Number	Inductance (uH)	Test Frequency (KHz)	DC Resistance (Ω Max)	Rated current (A)Max	Itemp (A)Max
SGRH5D28-2R6□-PF	2.6	10	18m	2.60	4.90
SGRH5D28-3R0□-PF	3	10	24m	2.40	4.40
SGRH5D28-4R2□-PF	4.2	10	31m	2.20	4.00
SGRH5D28-5R3□-PF	5.3	10	38m	1.90	3.60
SGRH5D28-6R2□-PF	6.2	10	45m	1.80	3.24
SGRH5D28-8R2□-PF	8.2	10	53m	1.60	2.92
SGRH5D28-100□-PF	10	10	65m	1.30	2.62
SGRH5D28-120□-PF	12	10	76m	1.20	2.35
SGRH5D28-150□-PF	15	10	0.103	1.10	2.11
SGRH5D28-180□-PF	18	10	0.11	1.00	1.89
SGRH5D28-220□-PF	22	10	0.122	0.90	1.70
SGRH5D28-270□-PF	27	10	0.175	0.85	1.53
SGRH5D28-330□-PF	33	10	0.189	0.75	1.37
SGRH5D28-390□-PF	39	10	0.212	0.70	1.23
SGRH5D28-470□-PF	47	10	0.26	0.62	1.10
SGRH5D28-560□-PF	56	10	0.305	0.58	1.04
SGRH5D28-680□-PF	68	10	0.355	0.52	0.98
SGRH5D28-820□-PF	82	10	0.463	0.46	0.93
SGRH5D28-101□-PF	100	10	0.52	0.42	0.84
SGRH5D28-121□-PF	120	10	0.85	0.40	0.75
SGRH5D28-151□-PF	150	10	0.956	0.35	0.68

Note:

- (1). All test data is referenced to 25°C ambient.
- (2). Operating Temperature Range-25°C to +105°C.
- (3). DC current(A)that will cause an approximate ΔT of 40°C.
- (4). DC current(A)that will cause L_o to drop approximately 35%.
- (5). □Tolerance of inductance $\pm 10\%$ (K) $\pm 20\%$ (M) $\pm 30\%$ (N)

SMD POWER CHOKE-SGRH Series
Electrical Characteristics

Part Number	Inductance (uH)	Test Frequency (KHz)	DC Resistance (ΩMax)	Rated current (A)Max	Itemp (A)Max
SGRH6D28-3R0□-PF	3.0	10	24m	3.00	4.70
SGRH6D28-3R9□-PF	3.9	10	27m	2.60	4.50
SGRH6D28-5R0□-PF	5.0	10	31m	2.40	4.00
SGRH6D28-6R0□-PF	6.0	10	35m	2.25	3.60
SGRH6D28-7R3□-PF	7.3	10	54m	2.10	3.23
SGRH6D28-8R6□-PF	8.6	10	58m	1.85	2.90
SGRH6D28-100□-PF	10	10	65m	1.70	2.60
SGRH6D28-120□-PF	12	10	70m	1.55	2.34
SGRH6D28-150□-PF	15	10	84m	1.40	2.10
SGRH6D28-180□-PF	18	10	95m	1.32	1.89
SGRH6D28-220□-PF	22	10	0.128	1.20	1.70
SGRH6D28-270□-PF	27	10	0.142	1.05	1.62
SGRH6D28-330□-PF	33	10	0.165	0.97	1.37
SGRH6D28-390□-PF	39	10	0.21	0.86	1.23
SGRH6D28-470□-PF	47	10	0.238	0.80	1.17
SGRH6D28-560□-PF	56	10	0.277	0.73	1.11
SGRH6D28-680□-PF	68	10	0.304	0.65	0.99
SGRH6D28-820□-PF	82	10	0.39	0.60	0.89
SGRH6D28-101□-PF	100	10	0.535	0.54	0.80
SGRH6D28-121□-PF	120	10	0.58	0.45	0.72
SGRH6D28-151□-PF	150	10	0.615	0.42	0.68

Note:

- (1). All test data is referenced to 25°C ambient.
- (2). Operating Temperature Range-25°C to +105°C.
- (3). DC current(A)that will cause an approximate ΔT of 40°C.
- (4). DC current(A)that will cause L_o to drop approximately 35%.
- (5). □ Tolerance of inductance $\pm 10\%$ (K) $\pm 20\%$ (M) $\pm 30\%$ (N)

SMD POWER CHOKE-SGRH Series
Electrical Characteristics

Part Number	Inductance (uH)	Test Frequency (KHz)	DC Resistance (Ω Max)	Rated current (A)Max	Itemp (A)Max
SGRH6D38-3R3□-PF	3.3	10	20m	3.50	4.00
SGRH6D38-5R0□-PF	5	10	24m	2.90	3.80
SGRH6D38-6R2□-PF	6.2	10	27m	2.50	3.60
SGRH6D38-7R4□-PF	7.4	10	31m	2.30	3.50
SGRH6D38-8R7□-PF	8.7	10	34m	2.20	3.33
SGRH6D38-100□-PF	10	10	38m	2.00	3.20
SGRH6D38-120□-PF	12	10	53m	1.70	2.88
SGRH6D38-150□-PF	15	10	57m	1.60	2.59
SGRH6D38-180□-PF	18	10	92m	1.50	2.43
SGRH6D38-220□-PF	22	10	96m	1.30	2.18
SGRH6D38-270□-PF	27	10	0.109	1.20	1.96
SGRH6D38-330□-PF	33	10	0.124	1.10	1.76
SGRH6D38-390□-PF	39	10	0.138	1.00	1.67
SGRH6D38-470□-PF	47	10	0.155	0.95	1.50
SGRH6D38-560□-PF	56	10	0.202	0.85	1.35
SGRH6D38-680□-PF	68	10	0.234	0.75	1.21
SGRH6D38-820□-PF	82	10	0.324	0.70	1.08
SGRH6D38-101□-PF	100	10	0.358	0.65	0.97

Note:

- (1). All test data is referenced to 25°C ambient.
- (2). Operating Temperature Range-25°C to +105°C.
- (3). DC current(A)that will cause an approximate Δ T of 40°C.
- (4). DC current(A)that will cause Lo to drop approximately 35%.
- (5). □Tolerance of inductance \pm 10%(K) \pm 20%(M) \pm 30%(N)

SMD POWER CHOKE-SGRH Series
PACKAGING

1. Configuration.

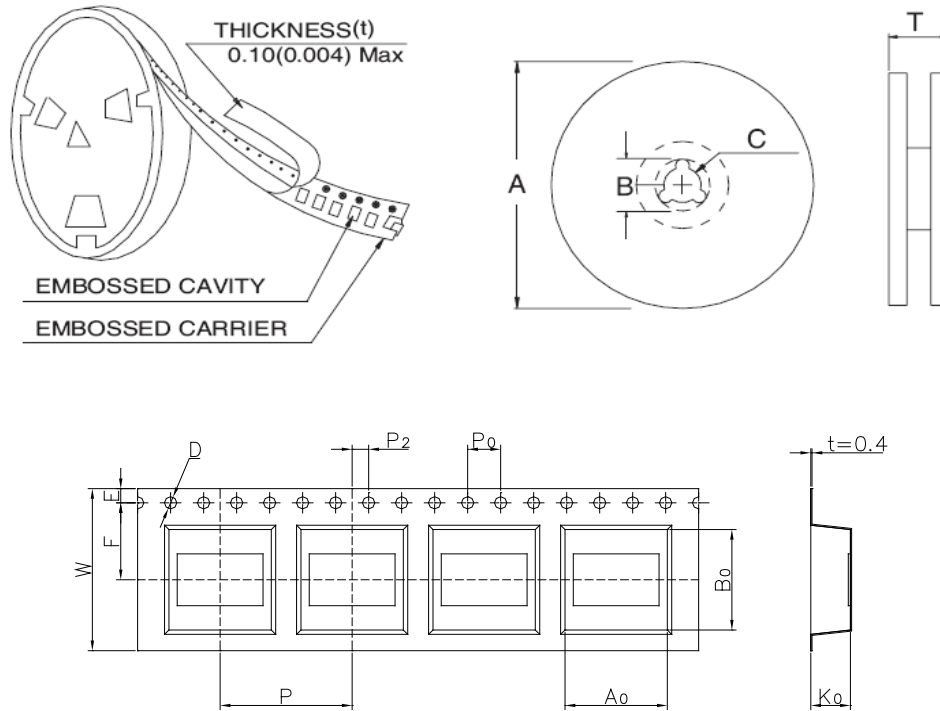

2. Dimension in mm

TYPE	A	B	C	T	FIG
12mm	178	21	13±0.8	16.4	1
16mm	178	21	13±0.8	20.4	1
12mm	330	100	21±0.8	16.4	2
16mm	330	100	21±0.8	20.4	2

TYPE	Ao(mm)	Bo(mm)	Ko(mm)	W(mm)	P(mm)	PCS/REEL
SGRH2D08	3.3±0.1	3.3±0.1	1.3±0.1	12±0.3	8±0.1	1000
SGRH2D11	3.3±0.1	3.3±0.1	1.6±0.1	12±0.3	8±0.1	1000
SGRH2D14	3.3±0.1	3.3±0.1	1.6±0.1	12±0.3	8±0.1	1000
SGRH2D18	3.3±0.1	3.3±0.1	2.3±0.1	12±0.3	8±0.1	1000
SGRH3D16	4.2±0.1	4.2±0.1	2.1±0.1	12±0.3	8±0.1	3000
SGRH4D18	5.4±0.1	5.4±0.1	2.1±0.1	12±0.3	8±0.1	2000
SGRH4D28	5.4±0.1	5.4±0.1	3.1±0.1	12±0.3	8±0.1	2000
SGRH5D18	6.4±0.1	6.4±0.1	2.1±0.1	12±0.3	8±0.1	2000
SGRH5D28	6.4±0.1	6.4±0.1	3.1±0.1	12±0.3	8±0.1	2000
SGRH6D28	7.4±0.1	7.4±0.1	3.4±0.1	16±0.3	12±0.1	1000
SGRH6D38	7.4±0.1	7.4±0.1	4.2±0.1	16±0.3	12±0.1	1000