

SUNLEI TECHNOLOGY CORP.

SMD Power chokes- SCEP Series

SCEP series For High Current Use

Features

Various high power inductors are superior to be high saturation for surface mounting.



Applications

Power supply for VTR,OA equipment,
LCD television set,notebook PC,
portable communication,equipments,
DC/DC converters,etc.

Product Identification

SCEP 125U – 100 M -PF

SCEP: SERIES NAME

60:Dimensions CODE

B:RI CORE TYPE

100: INDUCTANCE CODE.

M: TOLERANCE, K=10% M=20%.

PF:Pb-Free

Dimensions (mm)

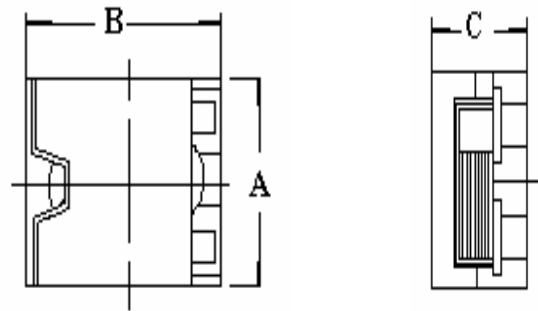

SERIES	A	B	C
SCEP104	10.4MAX	10.4MAX	4.5MAX
SCEP105	10.4MAX	10.4MAX	5.6MAX
SCEP125	12.9MAX	12.9MAX	5.8MAX
SCEP134	13.9MAX	13.9MAX	4.9MAX
SCEP147	14.9MAX	15.0MAX	8.1MAX

RECOMMENDER P.C.B LAYOUT

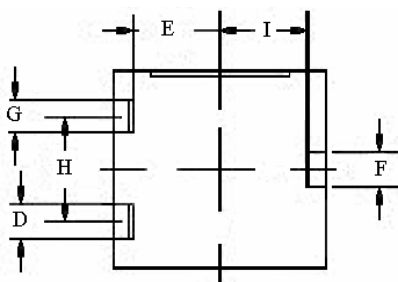

D	E	F	G	H	I
2.6	2.9	1.4	2.6	5.5	3.8
2.6	2.9	1.4	2.6	5.5	3.8
2.6	4.0	2.5	2.6	7.0	4.2
2.6	5.0	2.5	2.6	7.0	4.6
2.8	5.0	2.5	2.8	9.0	5.5

SMD Power chokes- SCEP Series

Electrical Characteristics

Part Number	Inductance (μ H)	Test Frequency (Hz)	DC Resistance (m Ω Max)	Rated current (A)Max	Itemp(A) Max
SCEP104S-0R22□-PF	0.22	100	2.6	39.6	23.0
SCEP104S-0R45□-PF	0.45	100	3.7	27.6	17.0
SCEP104S-0R8□-PF	0.8	100	5.9	20.7	14.0
SCEP104S-1R3□-PF	1.3	100	11.8	16.6	10.5
SCEP104S-1R8□-PF	1.8	100	18.6	13.3	8.0
SCEP104S-2R5□-PF	2.5	100	21.8	11.8	7.4
SCEP104L-0R36□-PF	0.36	100	2.6	24.2	22.0
SCEP104L-0R8□-PF	0.8	100	3.7	16.2	15.0
SCEP104L-1R4□-PF	1.4	100	5.9	12.2	13.5
SCEP104L-2R2□-PF	2.2	100	11.8	9.8	10.5
SCEP104L-3R2□-PF	3.2	100	18.6	8.1	8.0
SCEP104L-4R3□-PF	4.3	100	21.8	7.0	7.2

Note:

- (1). All test data is referenced to 25°C ambient.
- (2). Operating Temperature Range-55°C to +105°C.
- (3). DC current(A)that will cause an approximate Δ T of 40°C.
- (4). DC current(A)that will cause Lo to drop approximately 25%.
- (5). □Tolerance of inductance \pm 20%(M) \pm 30%(N)

SMD Power chokes- SCEP Series

Electrical Characteristics

Part Number	Inductance (μ H)	Test Frequency (Hz)	DC Resistance (m Ω Max)	Rated current (A)Max	Itemp(A) Max
SCEP105S-0R2□-PF	0.22	100	2.6	40	20.0
SCEP105S-0R45□-PF	0.45	100	3.2	26.4	18.0
SCEP105S-0R8□-PF	0.8	100	4.1	20.8	14.0
SCEP105S-1R3□-PF	1.3	100	5.3	16.8	13.0
SCEP105S-1R8□-PF	1.8	100	7.5	13.8	11.5
SCEP105S-2R5□-PF	2.5	100	10.5	11.8	9.0
SCEP105S-3R2□-PF	3.2	100	12.4	10.5	8.0
SCEP105S-4R0□-PF	4	100	18	9.3	7.5
SCEP105S-5R0□-PF	5	100	23.8	8.4	6.7
SCEP105L-0R3□-PF	0.36	100	1.7	24	21.0
SCEP105L-0R8□-PF	0.8	100	2.4	16	18.0
SCEP105L-1R4□-PF	1.4	100	4.1	12	14.0
SCEP105L-2R2□-PF	2.2	100	5.3	9.6	13.0
SCEP105L-3R2□-PF	3.2	100	7.5	7.8	10.5
SCEP105L-4R3□-PF	4.3	100	10.5	6.8	9.0
SCEP105L-5R7□-PF	5.7	100	12.4	5.8	8.0
SCEP105L-7R2□-PF	7.2	100	18	5.3	7.8
SCEP105L-8R8□-PF	8.8	100	23.8	4.5	7.0
SCEP105H-0R15□-PF	0.15	100	1.7	55.0	20.0
SCEP105H-0R3□-PF	0.3	100	2.4	40.0	18.8
SCEP105H-0R5□-PF	0.5	100	4.1	30.4	15.0
SCEP105H-0R8□-PF	0.8	100	5.3	25.2	13.5
SCEP105H-1R2□-PF	1.2	100	7.5	21.0	11.0
SCEP105H-1R5□-PF	1.5	100	10.5	18.0	8.5
SCEP105H-2R0□-PF	2	100	12.4	15.8	8.0
SCEP105H-2R5□-PF	2.5	100	18	14.0	7.8
SCEP105H-3R0□-PF	3	100	23.8	12.6	7.2

Note:

- (1). All test data is referenced to 25°C ambient.
- (2). Operating Temperature Range-55°C to +105°C.
- (3). DC current(A)that will cause an approximate Δ T of 40°C.
- (4). DC current(A)that will cause Lo to drop approximately 25%.
- (5). □Tolerance of inductance \pm 20%(M) \pm 30%(N)

SMD Power chokes- SCEP Series

Electrical Characteristics

Part Number	Inductance (μ H)	Test Frequency (Hz)	DC Resistance (m Ω Max)	Rated current (A)Max	Itemp(A) Max
SCEP125-1R2□-PF	1.2	100	2.5	17.0	21.0
SCEP125-1R5□-PF	1.5	100	2.5	14.0	17.0
SCEP125-2R5□-PF	2.5	100	3.4	10.0	15.0
SCEP125-4R0□-PF	4	100	5.4	8.3	14.0
SCEP125-6R0□-PF	6	100	8	6.7	12.0
SCEP125-8R2□-PF	8.2	100	11.4	5.8	10.0
SCEP125-100□-PF	10	100	13.5	5.0	9.0
SCEP125H-1R0□-PF	1	100	2.5	20	20.00
SCEP125H-1R8□-PF	1.8	100	3.4	15.3	13.00
SCEP125H-2R8□-PF	2.8	100	5.4	12.3	12.20
SCEP125H-4R0□-PF	4	100	8	10.3	11.80
SCEP125H-5R6□-PF	5.6	100	11.4	8.8	9.80
SCEP125H-7R2□-PF	7.2	100	13.5	7.8	8.80
SCEP125U-0R3□-PF	0.3	100	1.8	35	23.50
SCEP125U-0R6□-PF	0.6	100	2.5	30.2	18.80
SCEP125U-0R8□-PF	0.8	100	2.5	27.2	17.80
SCEP125U-1R4□-PF	1.4	100	3.4	20.8	14.00
SCEP125U-2R2□-PF	2.2	100	5.4	14.8	13.50
SCEP125U-3R2□-PF	3.2	100	8	12.8	13.00
SCEP125U-4R3□-PF	4.3	100	11.4	11	10.50
SCEP125U-5R6□-PF	5.6	100	13.5	9.5	9.00

Note:

- (1). All test data is referenced to 25°C ambient.
- (2). Operating Temperature Range-55°C to +105°C.
- (3). DC current(A)that will cause an approximate Δ T of 40°C.
- (4). DC current(A)that will cause Lo to drop approximately 25%.
- (5). □Tolerance of inductance \pm 20%(M) \pm 30%(N)

SMD Power chokes- SCEP Series

Electrical Characteristics

Part Number	Inductance (μ H)	Test Frequency (Hz)	DC Resistance (m Ω Max)	Rated current (A)Max	Itemp(A) Max
SCEP134S-0R4□-PF	0.4	100	2.5	32.0	19.0
SCEP134S-0R9□-PF	0.9	100	3.2	21.6	17.0
SCEP134S-1R6□-PF	1.6	100	4	16.0	16.0
SCEP134S-2R5□-PF	2.5	100	6.6	12.8	12.5
SCEP134S-3R6□-PF	3.6	100	10.8	10.9	10.8
SCEP134S-4R8□-PF	4.8	100	12	9.3	9.8
SCEP134S-6R4□-PF	6.4	100	16.3	8.0	8.5
SCEP134S-8R0□-PF	8.0	100	18.4	7.2	7.0
SCEP134H-0R3□-PF	0.3	100	2.5	35.0	18.0
SCEP134H-0R7□-PF	0.7	100	3.2	29.6	17.0
SCEP134H-1R2□-PF	1.2	100	4	21.0	15.0
SCEP134H-1R8□-PF	1.8	100	6.6	17.6	13.6
SCEP134H-2R7□-PF	2.7	100	10.8	14.7	12.0
SCEP134H-3R6□-PF	3.6	100	12	12.5	10.0
SCEP134H-4R8□-PF	4.8	100	16.3	11.0	9.0
SCEP134H-6R0□-PF	6.0	100	18.4	9.6	8.0

Note:

- (1). All test data is referenced to 25°C ambient.
- (2). Operating Temperature Range-55°C to +105°C.
- (3). DC current(A)that will cause an approximate Δ T of 40°C.
- (4). DC current(A)that will cause Lo to drop approximately 25%.
- (5). □Tolerance of inductance \pm 10%(K) \pm 20%(M) \pm 30%(N)

SMD Power chokes- SCEP Series

Electrical Characteristics

Part Number	Inductance (μ H)	Test Frequency (Hz)	DC Resistance (m Ω Max)	Rated current (A)Max	Itemp(A) Max
SCEP147S-0R4□-PF	0.4	100	2.1	52.8	23.0
SCEP147S-0R9□-PF	0.9	100	2.65	36.0	18.0
SCEP147S-1R5□-PF	1.5	100	3.5	27.2	16.0
SCEP147S-2R4□-PF	2.4	100	3.9	22.4	13.0
SCEP147S-3R4□-PF	3.4	100	5.5	18.4	12.3
SCEP147S-4R7□-PF	4.7	100	7.5	15.2	12.0
SCEP147S-6R1□-PF	6.1	100	7.8	14.8	11.0
SCEP147S-7R7□-PF	7.7	100	9.85	12.4	10.0
SCEP147S-9R5□-PF	9.5	100	13.3	11.2	9.3
SCEP147L-0R5□-PF	0.5	100	2.1	39.6	24.0
SCEP147L-1R1□-PF	1.1	100	2.65	26.4	22.0
SCEP147L-2R0□-PF	2	100	3.5	19.6	19.5
SCEP147L-3R1□-PF	3.1	100	3.9	16.0	16.2
SCEP147L-4R5□-PF	4.5	100	5.5	13.6	14.0
SCEP147L-6R1□-PF	6.1	100	7.5	11.6	13.5
SCEP147L-8R0□-PF	8.0	100	7.8	10.0	11.5
SCEP147L-100□-PF	10.0	100	9.85	9.2	10.2
SCEP147L-120□-PF	12.0	100	13.3	8.0	9.0
SCEP147H-0R3□-PF	0.3	100	2.1	70.0	23.0
SCEP147H-0R7□-PF	0.7	100	2.65	46.4	20.0
SCEP147H-1R2□-PF	1.2	100	3.5	35.7	19.5
SCEP147H-1R8□-PF	1.8	100	3.9	29.6	16.5
SCEP147H-2R6□-PF	2.6	100	5.5	24.4	14.0
SCEP147H-3R5□-PF	3.5	100	7.5	20.8	13.5
SCEP147H-4R7□-PF	4.7	100	7.8	17.6	11.5
SCEP147H-5R9□-PF	5.9	100	9.85	16.4	10.5
SCEP147H-7R3□-PF	7.3	100	13.3	14.6	9.0

Note:

- (1). All test data is referenced to 25°C ambient.
- (2). Operating Temperature Range-55°C to +105°C.
- (3). DC current(A)that will cause an approximate Δ T of 40°C.
- (4). DC current(A)that will cause Lo to drop approximately 25%.
- (5). □Tolerance of inductance \pm 10%(K) \pm 20%(M) \pm 30%(N)

PACKAGING

1. Configuration.

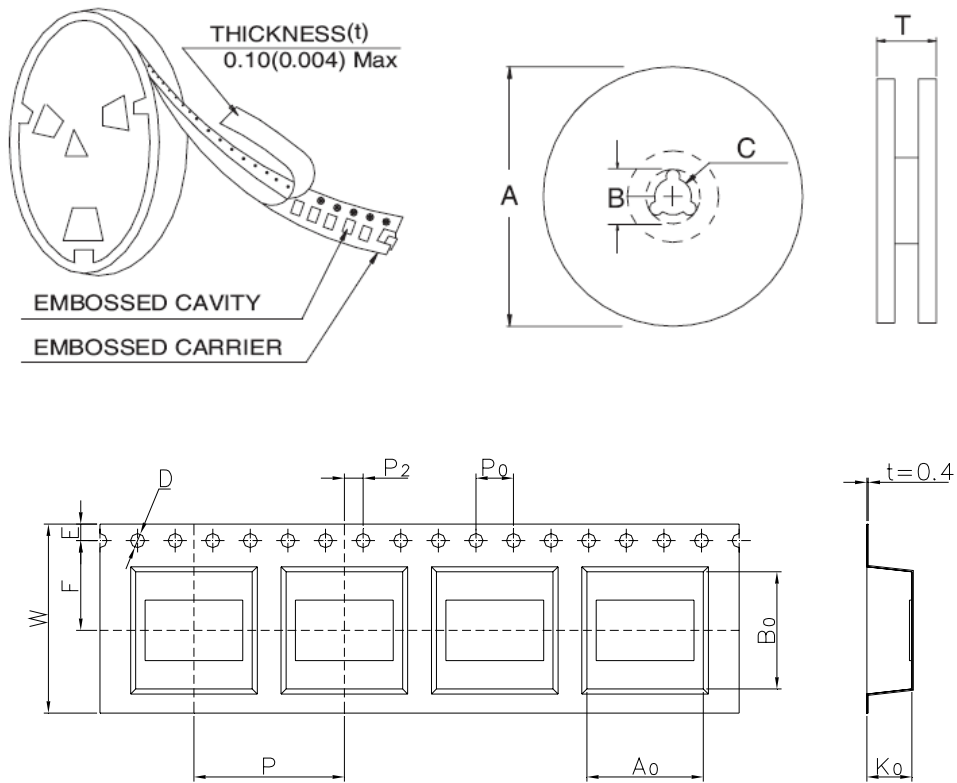

2. Dimension in mm

TYPE	A	B	C	T
12mm	330	100	21±0.8	16.4
16mm	330	100	21±0.8	20.4
24mm	330	100	21±0.8	28.4
32mm	330	100	21±0.8	36.4

SERIES	Ao(mm)	Bo(mm)	Ko(mm)	W(mm)	P(mm)	PCS/REEL
SCEP104	10.5±0.1	10.7±0.1	5.2±0.1	24±0.3	16±0.1	500
SCEP105	10.5±0.1	10.7±0.1	6.0±0.1	24±0.3	16±0.1	500
SCEP125	12.9±0.1	12.9±0.1	6.3±0.1	24±0.3	16±0.1	500
SCEP134	14.1±0.1	14.1±0.1	5.2±0.1	24±0.3	20±0.1	500
SCEP147	15.0±0.1	15.4±0.1	8.3±0.1	32±0.3	20±0.1	300